

HA15 DX

Articulating boom

- 24 ft 7 in (7.5 m) outreach
- 22 ft 8 in (6.9 m) up and over clearance
- Standard 4 Wheel drive
- 40 % gradeability
- 507 lb (230 kg) platform capacity



Haulotte® 

HA15 DX

The Haulotte® advantages

- Foam filled tyres standard
- Hydraulic differential lock for demanding rough terrain conditions
- 14 ft (4.25 m) turning radius for improved manoeuvrability
- Simple uncomplicated operational controls
- Work platform overload limiter increases safety
- Low weight for easy transportation
- Robust, reliable, easy to maintain design

STANDARD FEATURES

- Hatz diesel engine
- 4 wheel drive
- 180° platform rotation
- 5° slope tilt alarm
- AC electric power outlet in platform
- Emergency hand pump
- Free wheeling device
- Hourmeter
- Slewing block pin
- Towing hooks / lifting eyes

OPTIONS & ACCESSORIES

- Silent pack engine
- Travel alarm
- Rotating beacon
- Working light
- Catalytic exhaust
- Airline to cage
- Hostile environment kit
- Sandblast protection kit



ARTICULATING BOOM

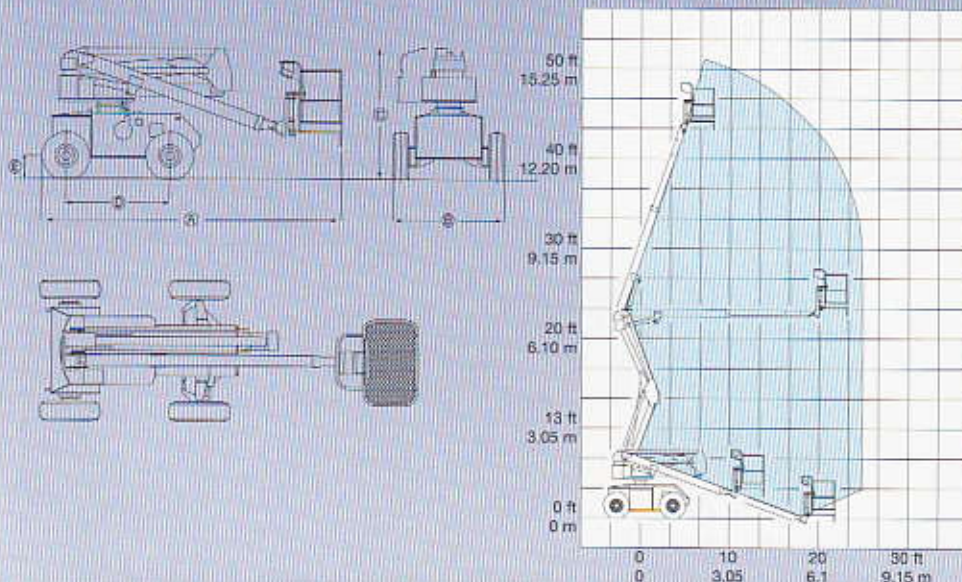

SPECIFICATIONS

Working Height	49'	15.0 m
Platform Height	43'	13.0 m
Horizontal Reach	24' 7"	7.5 m
Up and Over Clearance	22' 8"	6.9 m
Platform Capacity	507 lb	230 kg
A Length	18' 1"	5.52 m
B Width	6' 8"	2.03 m
C Stowed height	7' 9"	2.37 m
D Wheelbase	6' 3"	1.9 m
E Ground clearance	15"	37 cm
Platform size	59" x 30"	1.5 m x 0,76 m
Tailswing	0	0
Drive speed	0.6 / 3.1 mph	1 / 5 km/h
Outside turning radius	14'	4.25 m
Turntable Rotation (non continuous)	360°	
Platform rotation	180°	
Power source	Diesel 32 hp - 24 KW	
Controls	Proportional	
Gradeability	40 %	
Tyres (Foam Filled)	275 / 80	
Hydraulic tank	40 gallons	150 l
Fuel tank	16 gallons	60 l
Weight	12.430 lb	5.650 kg

Distributed by :

Haulotte®  

THE HEIGHT OF QUALITY

Pinguely - Haulotte 

Worldwide Headquarters

La Péronnière • B.P. 9
42152 L'HORME • France
Tel. +33 (0)4 77 29 24 24
Fax +33 (0)4 77 29 43 95
E-Mail: haulotte@haulotte.com
Web: http://www.haulotte.com