

OPTIMUM 6 OPTIMUM 8



Optimum compactness

- Width of 76 cm to operate in the most congested areas
- Compact stowed height for easy access through standard doorways

Exceptional productivity:

- Driveable at full height
- Load capacity up to 270 kg (06)
- Extended platform
- High Operating Autonomy
- Robust, reliable, easy to maintain

Optimum 8

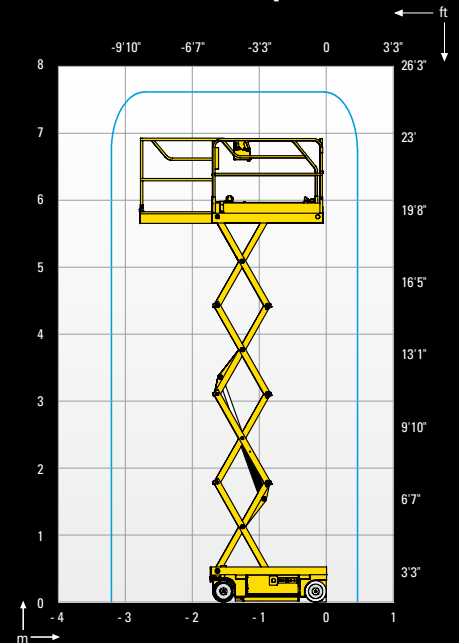

OPTIMUM 6 / OPTIMUM 8

ELECTRIC SCISSOR LIFTS

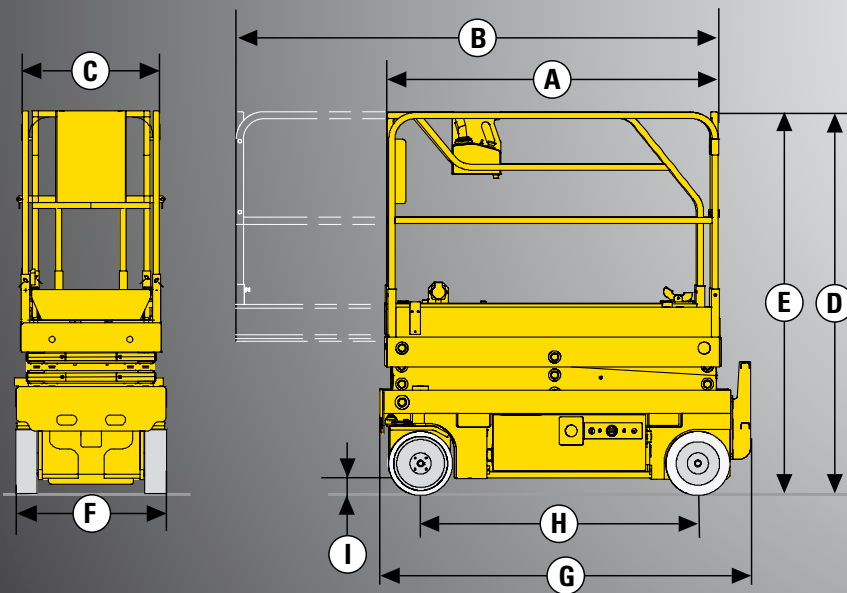

TECHNICAL DATA

	Optimum 6	Optimum 8
Working height	6.45 m	7.76 m
Platform height	4.45 m	5.76 m
Driveable at full height up to	4.45 m	5.76 m
Lift capacity - inside	270 kg	230 kg
Lift capacity - outside	270 kg	N/A
A - Platform length - outside	1.73 m	1.73 m
B - Platform length - extended	2.65 m	2.65 m
Length - extension	0.92 m	0.92 m
C - Platform width - outside	0.68 m	0.68 m
D - Storage height	1.9 m	2 m
E - Height - stowed	1.9 m	2 m
F - Overall width	0.76 m	0.76 m
G - Length	1.88 m	1.88 m
H - Wheelbase	1.38 m	1.38 m
I - Ground clearance - Centre	8 cm	8 cm
Ground clearance - Pothole guards deployed	2.2 cm	2.2 cm
Drive speed	0.6 - 4.5 km/h	0.6 - 4.5 km/h
Gradeability	25 %	25 %
Tilt	2 °	2 °
Lift / lower speed	35 / 20 s	32 / 23 s
Turning radius - outside	1.7 m	1.7 m
Tyres - non marking	12.5x4.25	12.5x4.25
Batteries	24 V - 185 Amph (C5)	24 V - 185 Amph (C5)
Hydraulic system capacity	20 l	20 l
Weight	1335 kg	1420 kg

STANDARD EQUIPMENT

- Pothole guards
- Battery charge indicator
- Proportional lift and drive
- Inside / outside use (Optimum 6)
- Swing out component tray
- Battery charger with automatic stop
- Solid non-marking tyres
- Free wheeling device
- Tilt controller
- Load Management System in the platform
- Manual platform lowering valve
- Integrated forklift pockets
- Towing hooks
- Horn
- Hourmeter

OPTIONS AND ACCESSORIES

- Flashing light
- Travel alarm
- Working light
- Power to platform
- Biodegradable hydraulic oil
- Folding guardrails



Haulotte 
GROUP